

# Medical electronics



**CONTICO**  
ELECTRONICS

# Medical Electronics

As a result of continuing high demand and innovation, medical electronics represents the fastest growing industrial passive electronics and semiconductor opportunity for suppliers, with the Home and Clinical segments all requiring improved components with advanced performance characteristics, smaller sized packaging, lower power consumption, and cost effectiveness which increases profitability.

Relative to the overall Industrial market, the medical electronics market is a small, but attractive and growing, market of opportunity for Contico Technologies, as healthcare shifts toward home-based applications, and as new product development continues. One major trend in medical electronics is the continued movement of patient care away from professional facilities, such as hospitals, into the home environment. This comes as a byproduct of advancing medical technology; but also from the healthcare provider point of view, the trend toward home patient care serves to improve the efficiency and reduce the costs incurred by doctors.



Contico Technologies can provide products for the medical environment:

- high quality power supplies
- driving transformers for Power MOS-fet's & IGBT's
- current sensors
- chokes and filters
- planar transformers and chokes in multi-layers technique.

Compliance with the applicable specialized standards and the use of UL-listed materials are the basis of each development. Contico does provide power solution designed to meet most stringent medical applications, providing safest EMI environment, while maintaining reliability and electrical characteristics, over long periods of time.

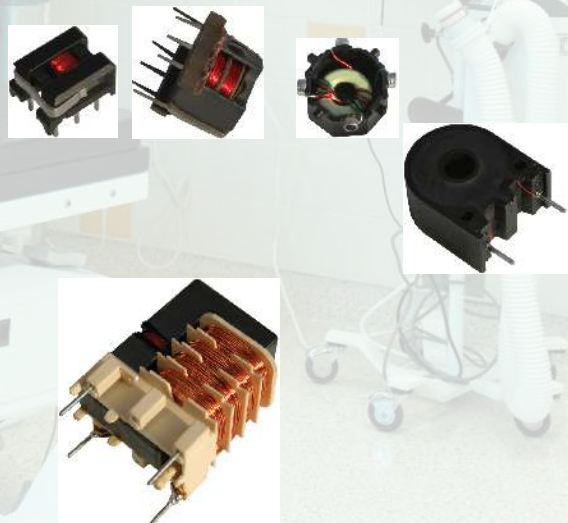

Customize your product - contact us!

# Product examples

## Power Supplies

- used for power medical instruments, are available in various forms: wall mount, desktop and open frame design.
- Client customization is possible!

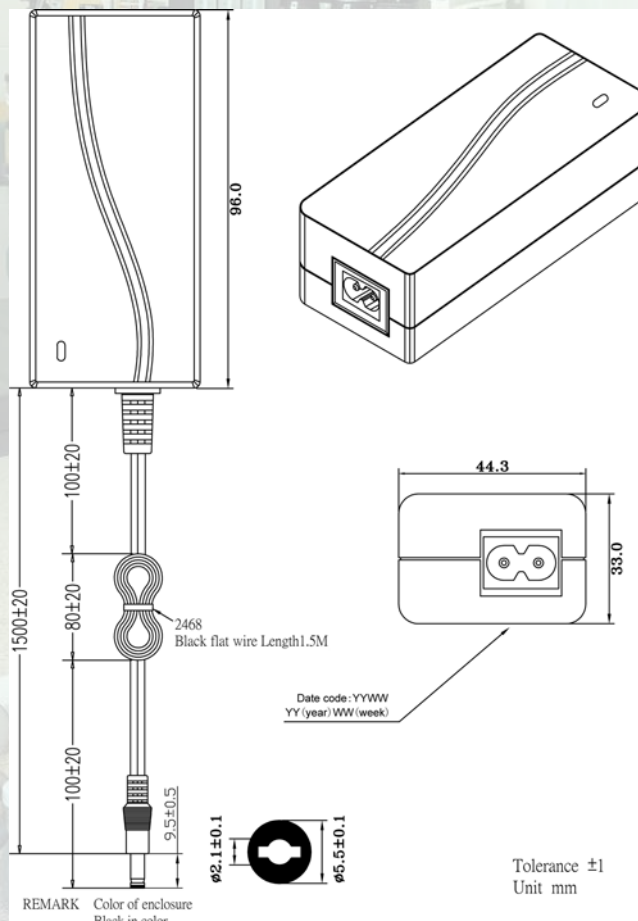
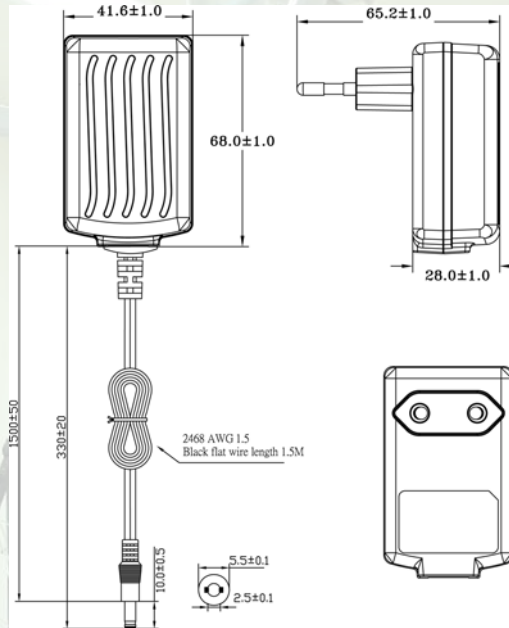

# SMD power chokes

- used for power medical instruments, are available in various forms
- Client customization is possible!

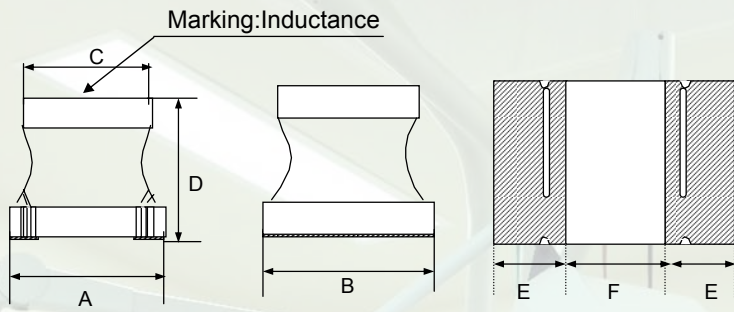

Dimensions:mm

A:	3.2±0.2
B:	2.5±0.2
C:	2.5±0.2
D:	2.0±0.4
E:	0.9
F:	1.3

# Wide band chokes

- used for power medical instruments, are available in various forms
- Client customization is possible!

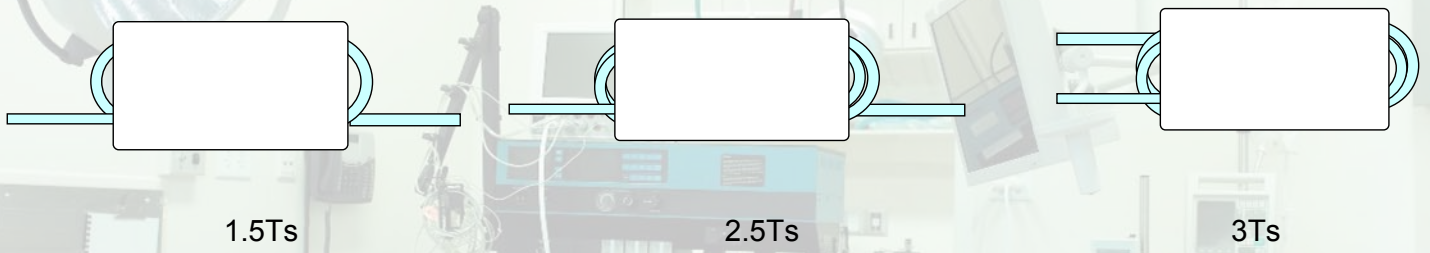

# Chip inductors

- used for power medical instruments, are available in various forms
- small size, low weight
- Client customization is possible!

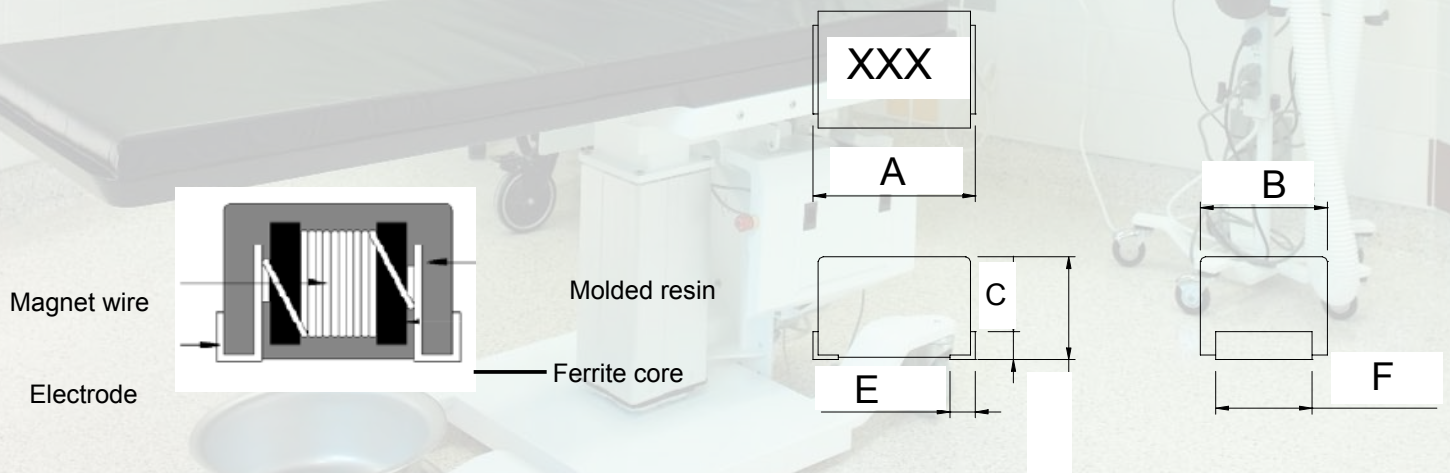

**For the complete product range please  
 access [www.conticoelectronics/download](http://www.conticoelectronics/download) or contact us!**

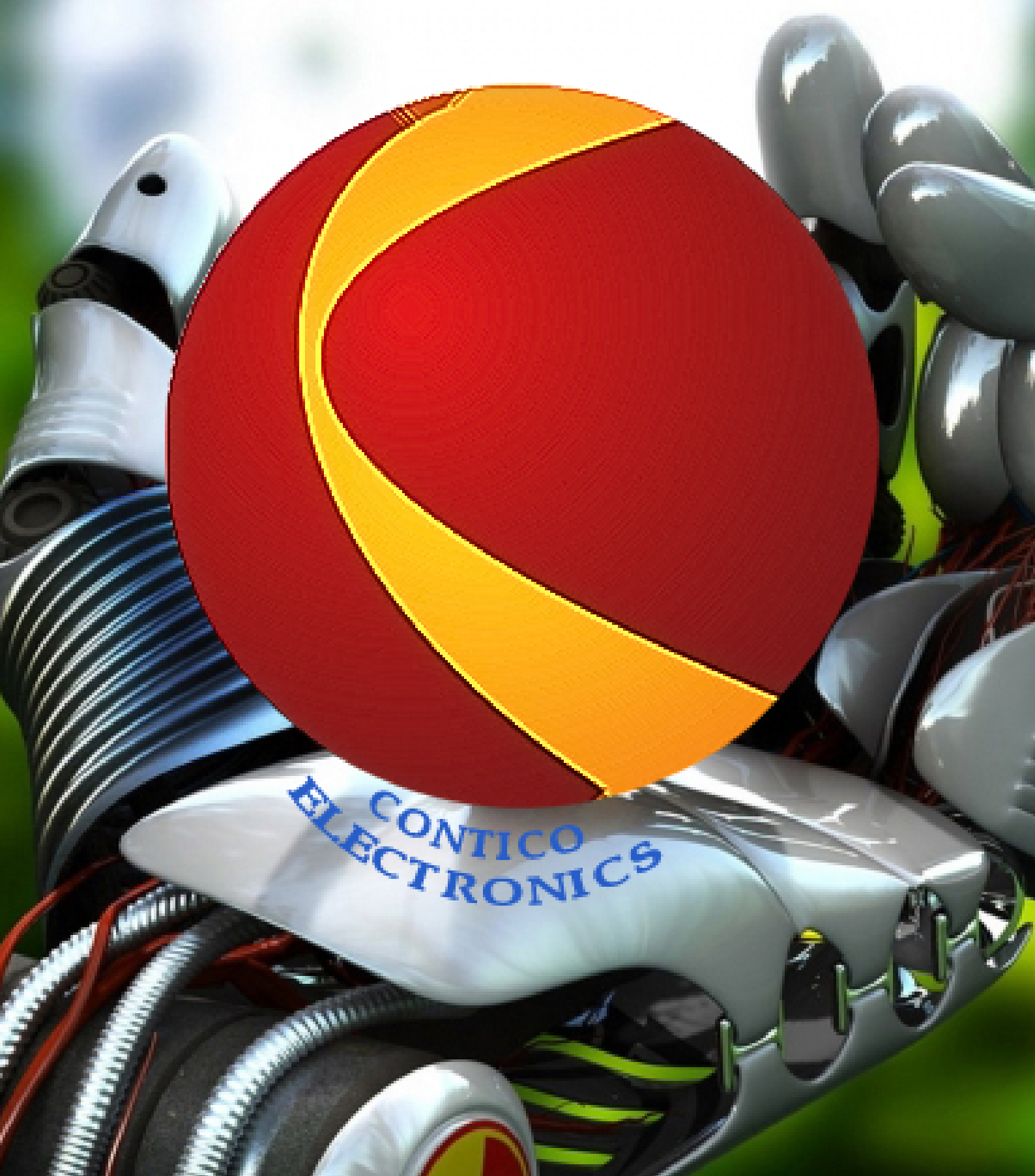

CONTICO Technologies & Contico Electronics . All Rights Reserved. CONTICO and CONTICO LOGO. CONTICO reserves the right to alter specifications without notice at any time.

### Romania Location

5A Lapusului str.  
Baia Mare 430053  
Maramures, Romania  
Tel: +40-262-212 500  
Fax : +40-362-415 050

### China Location

A1811,Fenglin International centre,  
Jixiang zhong Road ,Longgang district,  
Shenzhen,China  
Tel: +86 755 3383 0926

[www.conticoelectronics.com](http://www.conticoelectronics.com)